

STRAWBERRY

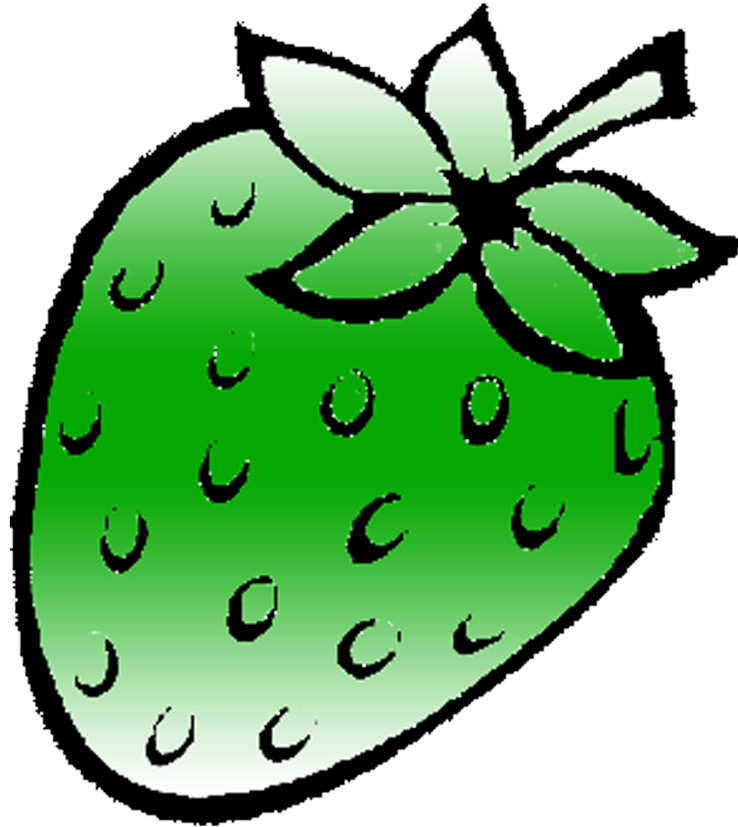

/strawberrydevelopers



/strawberry_app

For more visit:

Strawberrydevelopers.weebly.com

CENTROID

(Wires)

1.

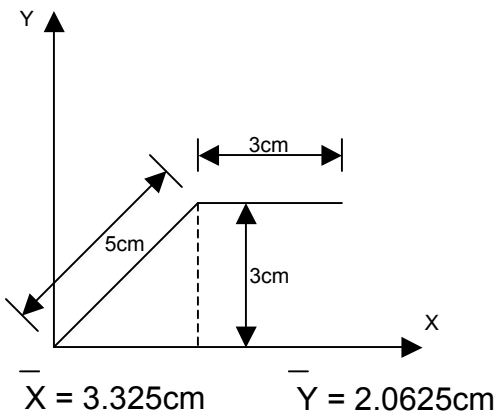

2.

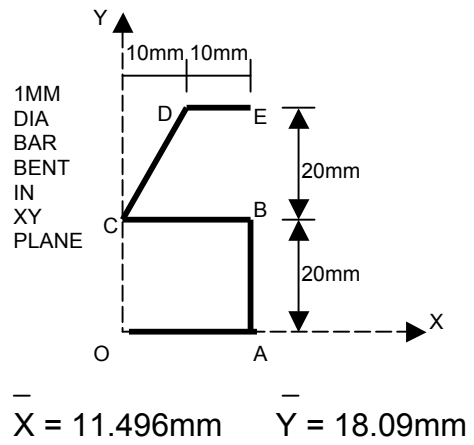

3.

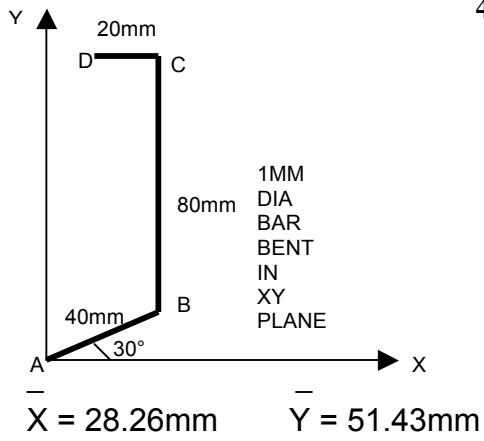

4.

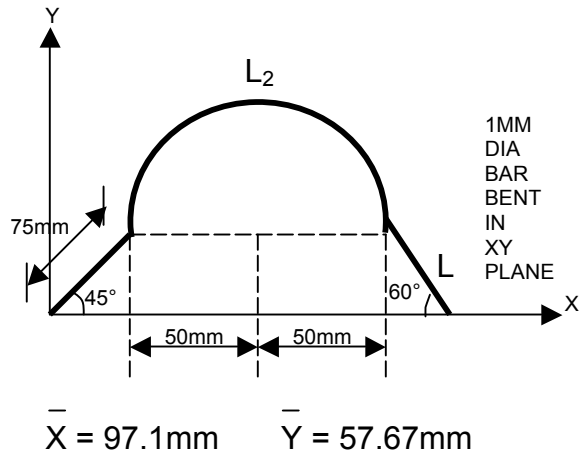

5.

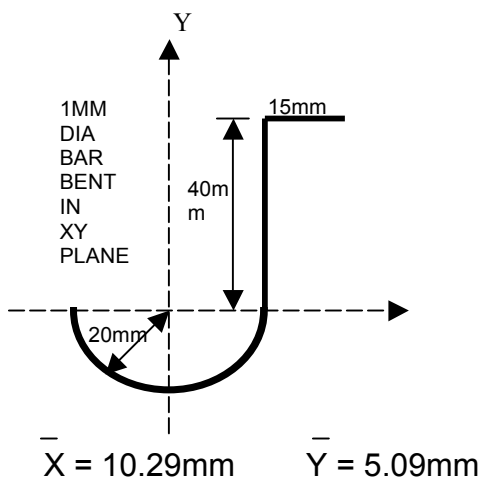

6.

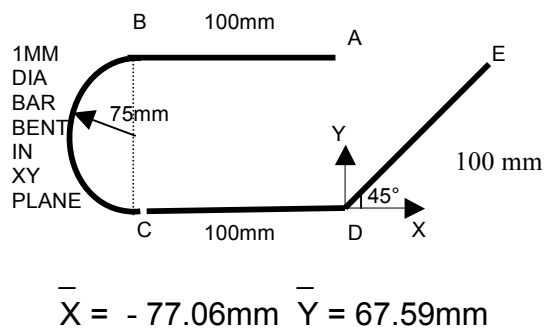

7.

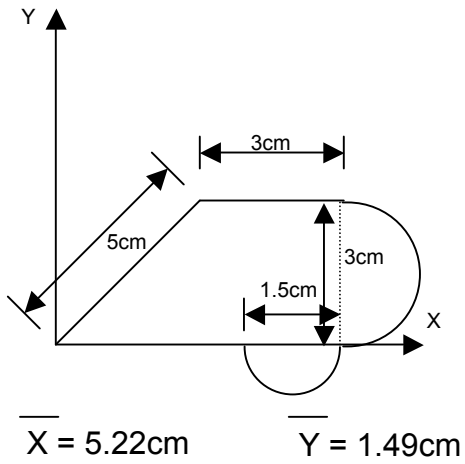

8.

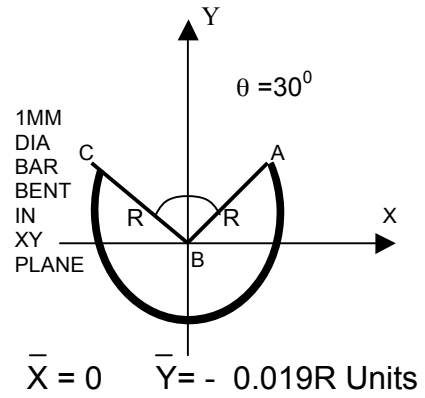

9. The figure shown below is formed of thin homogenous wire. Find the length 'l' of portion CE of the wire for which centre of gravity of figure is Take located at C. $l = \sqrt{3}r$ semicircle DE of radius 20 mm.

